

SG 5600

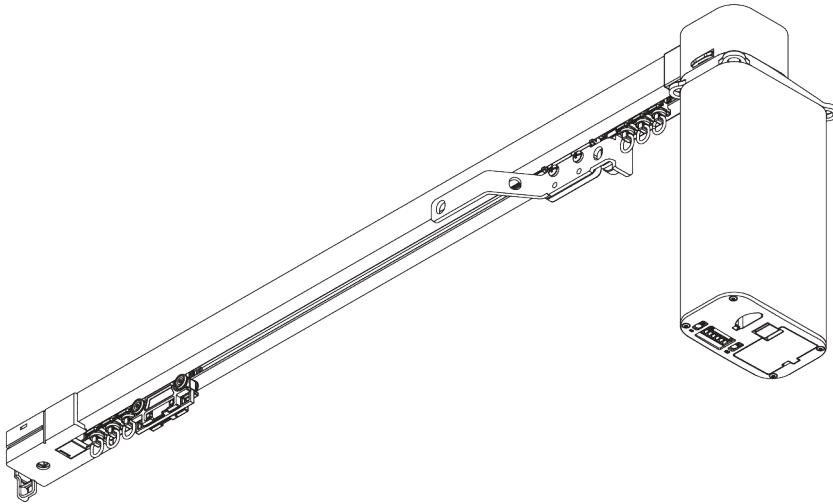

PRODUKTINFORMATIONEN

- **Bedienung:** Motor
- **Grösse:** S - L
- **Montage:** Decke, Wand, Nut
- **Farben:** weiss RAL 9016, schwarz RAL 9005 oder Aluminium farblos eloxiert, Sonderfarben möglich (Nutprofil nur weiss RAL 9016, schwarz RAL 9005 oder Sonderfarbe)
- **Stoffe:** siehe Silent Gliss Stoffkollektion

Merkmale:

- Leiser, schneller und kraftvoller Motor
- 2-Komponenten-Roller-Technologie (2C)
- Wave (2C)
- Vielfältige Steuerungsmöglichkeiten
- Touch & Go
- Manual Override inklusive permanentem Positionssensor
- Einfache Programmierung
- 100-250 AC und / oder 24 V DC in einem Motor
- Biegbar
- Biegbares Nutprofil

SYSTEMSPEZIFIKATIONEN

A. MASSE / GEWICHT

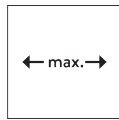

25 m



65 kg

Max. Vorhanggewicht mit 2C-Roller / Wave-2C-Rollerkordel

	2 m	4 m	6 m	8 m	10 m	12 m	15 m	18 m	21 m	25 m
	25	45	45	50	65	45	45	45	45	40
	25	45	45	50	65	45	45	45	45	40
	25	35	35	40	35	35	35	32	29	25
	25	35	35	40	35	35	35	32	29	25
	25	30	30	30	25	25	22	19	15	-
	25	30	30	30	25	25	22	19	15	-
	20	20	20	18	16	12	10	-	-	-
	20	20	20	18	16	12	10	-	-	-

(kg max.)

Max. Vorhanggewicht mit Wave Gleiterkordel oder Gleiter

	2 m	4 m	6 m	8 m	10 m
	20	25	25	25	20
	20	25	25	25	20
	20	20	20	20	15
	20	20	20	20	15
	20	20	20	15	10
	20	20	20	15	10
	20	20	15	8	-
	20	20	15	8	-

(kg max.)

B. PROFIL

Profil- und Biegeinformationen

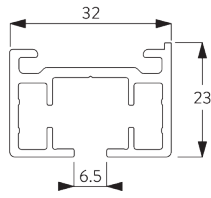

SG 10850

Profil

Radius: >25 cm

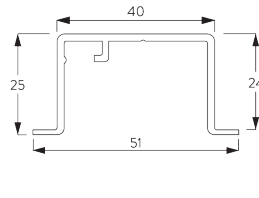

SG 10862

Nutprofil

Radius: 50 - 75 cm
 >75 cm auf Anfrage

C. MASSAUFNAHME

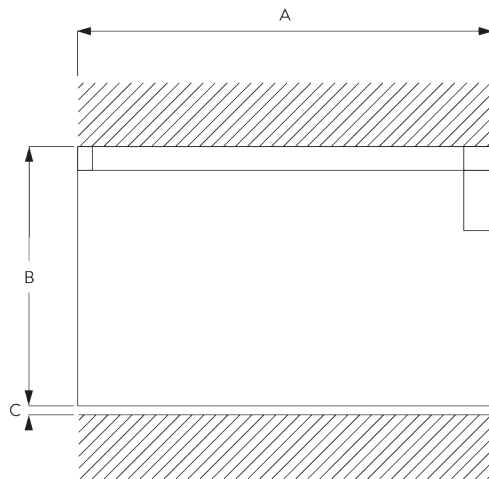

A: Systembreite

B: Systemhöhe

C: Abstand zwischen Boden und Behang

MONTAGE

A. MONTAGE- INFORMATIONEN

Detaillierte Montageinformationen siehe
Silent Gliss Website

Montagepunkte

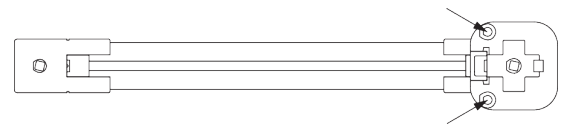
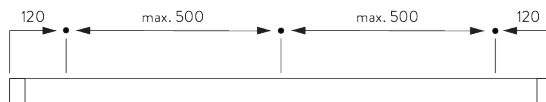

Motormaske zu fixieren (nur Deckenmontage).

B. DECKEN- MONTAGE

Spanner SG 3004

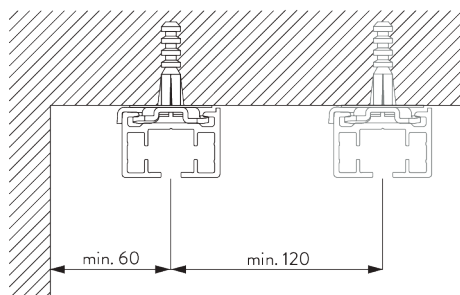

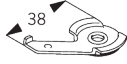

SG 3004
Spanner

Direkte Montage (nur 2C-Roller)

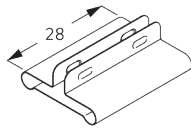
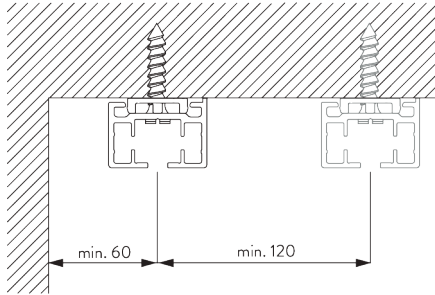

SG 7002
Profilschutz

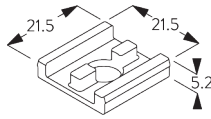

SG 10865
Montageplatte

C. WANDMONTAGE

Smart Fix

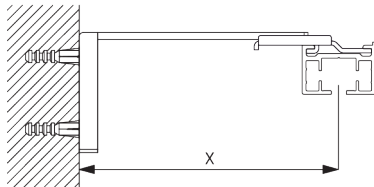

Smart Fix SG 11200 - SG 11205 und Träger SG 3041:
Benötigt Schraube SG 10492 (M4x8).

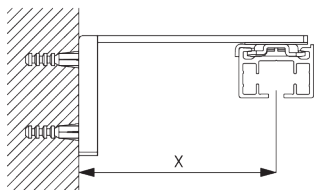

Smart Fix SG 11200 - SG 11205 und Spanner SG 3004:
Benötigt Schraube SG 10074 (M4x8).

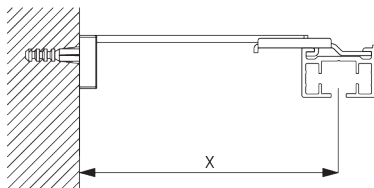

Square Smart Fix SG 11210 - SG 11215 und Träger SG 3041:
Benötigt Schraube SG 10492 (M4x8).

Smart Fix	X mm (SG 3041)	X mm (SG 3004)
SG 11200 / SG 11210	83	
SG 11201 / SG 11211	103	72
SG 11202 / SG 11212	123	92
SG 11203 / SG 11213	143	112
SG 11204 / SG 11214	173	142
SG 11205 / SG 11215	223	192
SG 11154	128-156	102-130
SG 11155	158-186	132-160
SG 11156	208-236	182-210

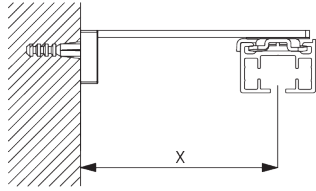

Square Smart Fix SG 11210 - SG 11215 und Spanner SG 3004:

Benötigt Schraube SG 10074 (M4x8).

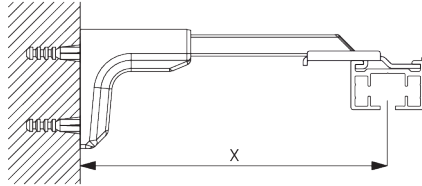

Universal Smart Fix SG 11154 - SG 11156 und Träger SG 3041:

Benötigt Schraube SG 10407 (M4x10).

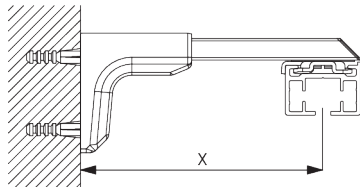

Universal Smart Fix SG 11154 - SG 11156 und Spanner SG 3004:

Benötigt Schraube SG 11158 (M4x12).

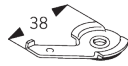

SG 3004
Spanner

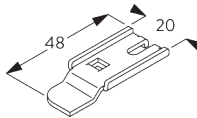

SG 3041
Träger



SG 10074
Senkschraube M4x8



SG 10407
Linsenschraube M4x10



SG 10492
Linsenschraube M4x8



SG 11158
Senkschraube M4x12

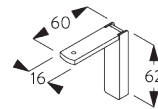

SG 11200
Smart Fix 60 mm

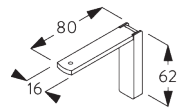

SG 11201
Smart Fix 80 mm

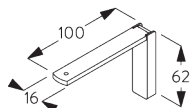

SG 11202
Smart Fix 100 mm

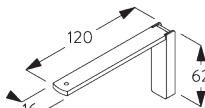

SG 11203
Smart Fix 120 mm

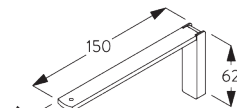

SG 11204
Smart Fix 150 mm

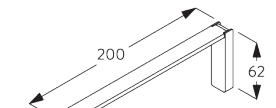

SG 11205
Smart Fix 200 mm

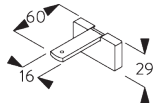

SG 11210
Square Smart Fix 60 mm

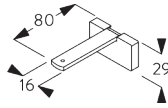

SG 11211
Square Smart Fix 80 mm

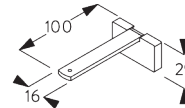

SG 11212
Square Smart Fix 100 mm

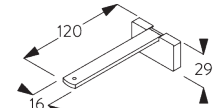

SG 11213
Square Smart Fix 120 mm

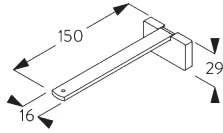

SG 11214
Square Smart Fix 150 mm

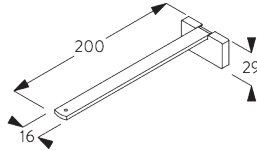

SG 11215
Square Smart Fix 200 mm

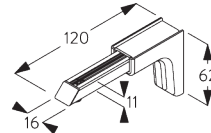

SG 11154
Universal Smart Fix 120 mm

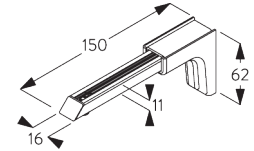

SG 11155
Universal Smart Fix 150 mm

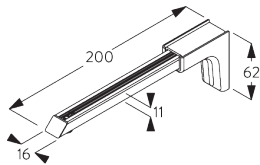

SG 11156
Universal Smart Fix 200 mm

D. NUTMONTAGE

Nutprofil SG 10862

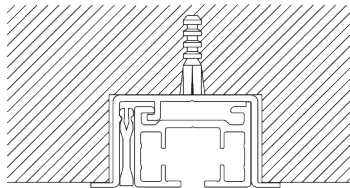

Eine Klammer SG 5118 pro Montagepunkt.

Detaillierte Nutmontage siehe Silent Gliss Website.

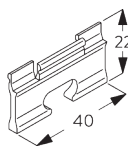

SG 5118
Klammer

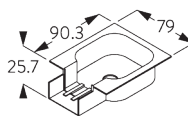

SG 10863
Nutmaske Motor

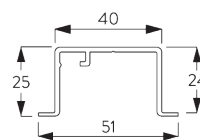

SG 10862
Nutprofil

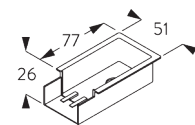

SG 10864
Nutmaske

Hohldecke

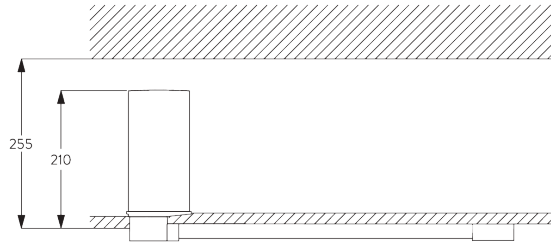

Profil mit Spanner SG 3004 montiert.

Für Montage / Programmierung ist Zugang zum Hohlraum notwendig.

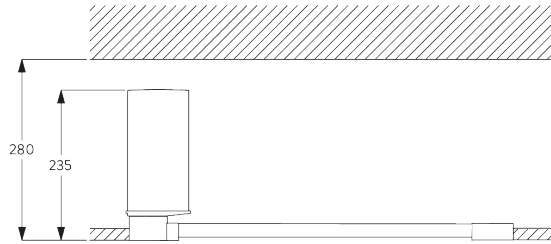

Nutprofil SG 10862 eingebaut.

Für Montage / Programmierung ist Zugang zum Hohlraum notwendig.

E. ABGEHÄNGTE MONTAGE

Hänger SG 6105

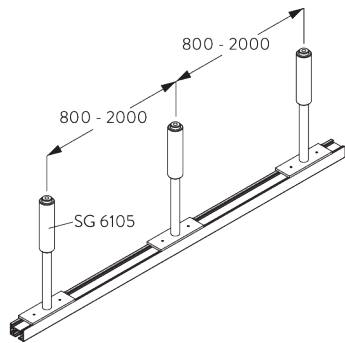

Das Gewicht des Vorhangs reduziert sich um 30 %.

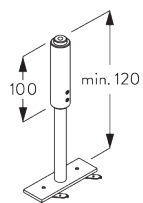

SG 6105

Hänger

V-Hänger SG 6107

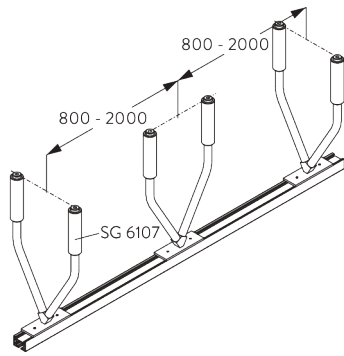

Das Gewicht des Vorhangs reduziert sich um 30 %.

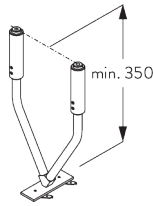

SG 6107
V-Hänger

SYSTEMOPTIONEN

A. WAVE

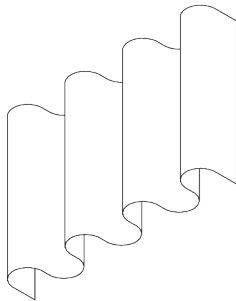

SG 6365



SG 10844

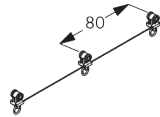

SG 10852



SG 10854



SG 10856



SG 10867



SG 10886



SG 10887

Standard Komponenten:

- SG 6365 Wave Hänger
- SG 10844 Wave Feststeller
- SG 10852 Wave-2C-Rollerkordel 80 mm
- SG 10854 Wave Vorläufer
- SG 10856 Wave Endstop
- SG 10867 Schraube
- SG 10886 Wave Überzugwagen
- SG 10887 Wave Überzugwagen

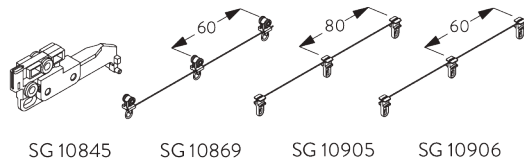

SG 10845 SG 10869 SG 10905 SG 10906

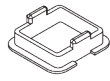

SG 10924

Optionale Komponenten:

- SG 10845 Wave Vorläufer 80 mm
- SG 10869 Wave-2C-Rollerkordel 60 mm (nicht 1-teilig)
- SG 10905 Wave Gleiterkordel 80 mm
- SG 10906 Wave Gleiterkordel 60 mm (nicht 1-teilig)
- SG 10924 Wave Feststeller

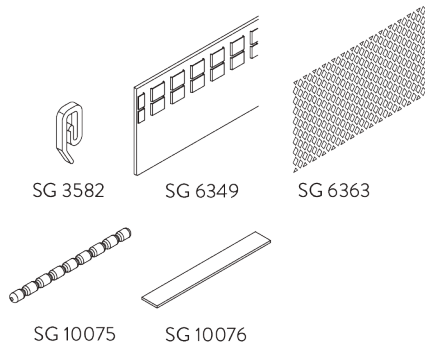

SG 3582 SG 6349 SG 6363
SG 10075 SG 10076

Vorhang Komponenten:

- SG 3582 Haken
- SG 6349 Wave Vorhangband
- SG 6363 Wave Bügelband
- SG 10075 Bleischnur 50 gr/m
- SG 10076 Beschwerung Seitensaum

Wave Paketbreite - 2C-Roller- / Gleiterkordel (Standard Komponenten)

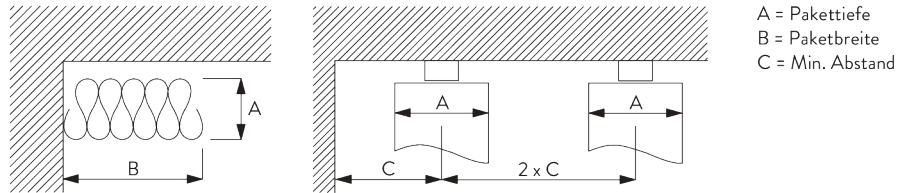

A = Pakettiefe
B = Paketbreite
C = Min. Abstand

Roller-/ Gleiterkordel SG 10852 / 10905	Zwischen- laschen	Stoffzugabe	Pakettiefe A	Paketbreite B*	Min. Abstand C
80	6	~2.1	140	210 pro Meter System	90
80	7	~2.3	160	210 pro Meter System	100

Roller-/ Gleiterkordel SG 10869 / 10906	Zwischen- laschen	Stoffzugabe	Pakettiefe A	Paketbreite B*	Min. Abstand C
60	4	~2.1	100	260 pro Meter System	70
60	5	~2.3	120	260 pro Meter System	80

*Paketgröße B plus 190 mm pro Vorhangpaket!

MOTOREN UND BEDIENUNGSARTEN

A. MOTOR- MERKMALE

Motor	SG 9060
Motoreigenschaften	
Soft-Start / Stop	•
Touch & Go	•
Manual Override	•
Modularer Funkempfänger (optional)	•
Elektronische Endposition	•
Elektronischer Umdrehungszähler (Umdrehungszahl unbegrenzt)	•
Zwei Zwischenpositionen möglich	•
Parallelschaltung möglich ohne zusätzliche Relais	•
High-end DC Motor mit bürstenloser Technologie	•
Permanenter Positionssensor (auch ohne Strom)	•
100 - 250 V AC und / oder 24 V DC in einem Motor	•
Anschlusskabel an Motor ansteckbar	•
IP Klasse	IP 40
Steuerungsmöglichkeiten	
Netzstrom	•
Potenzialfreie Kontakte	•
Potenzialfreie Kontakte kombinierbar mit SG Control L	•
SG Control L (mit Funkempfänger)	•
Smart by Silent Gliss (mit Smart Modul)	•
Geeignet für alle gängigen Hausautomationssysteme (mit passender Schnittstelle)	•

B. MOTOR- SPEZIFIKATIONEN

Motor	Motorabmessungen	Spannung AC	Spannung DC	Stromstärke	Frequenz	Geschwindigkeit / Sek.	Funkfrequenz Empfänger
SG 9060	L 206 x H 60 x T 96	100 - 250 V AC	24 V DC	1.3 - 0.5 A	50 - 60 Hz	21 cm / Sek.	-
SG 9060 mit SG Control L	L 226 x H 60 x T 96	100 - 250 V AC	24 V DC	1.3 - 0.5 A	50 - 60 Hz	21 cm / Sek.	868/915 MHz
SG 9060 mit Smart by SG	L 226 x W 60 x D 96	100 - 250 V AC	24 V DC	1.3 - 0.5 A	50 - 60 Hz	21 cm / Sek.	Smart by SG

Siehe Website für
Schaltschema.

C. FUNK- EMPFÄNGER

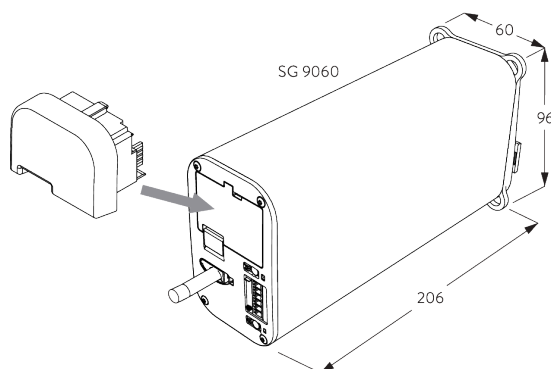

Motor SG 9060 kann mit folgendem Funkempfänger ausgestattet werden:

- SG 9063 Funkmodul
- SG 11270 Smart Modul

Siehe Katalog "Steuerungen".

D. BEDIENUNGS- ARTEN

Siehe Katalog "Steuerungen" für mehr Details.

Wandschalter



Bedienbar mit drahtgebundenem Wandschalter.

SG Control L



Verschiedene Funkfernsteuerungen erhältlich.



Silent Gliss Move App.

Smart by Silent Gliss



Offenes Zwei-Weg-Kommunikationssystem, das eine problemlose Integration der Produkte mit den meisten gängigen Gebäudemanagementsystemen ermöglicht. Smart-Modul SG 11270 erforderlich.

E. SCHALTSCHHEMA



Siehe Silent Gliss Website.

KOMPONENTEN

A. STANDARD KOMPONENTEN

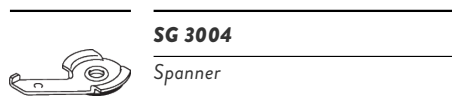

SG 3004

Spanner



SG 3581

Haken

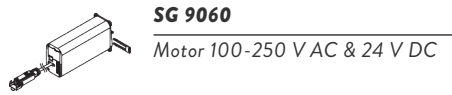

SG 9060

Motor 100-250 V AC & 24 V DC



SG 9917

Hirschmann Kupplung STAK 3 N

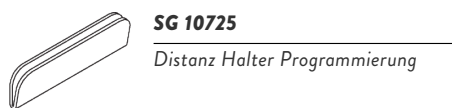

SG 10725

Distanz Halter Programmierung

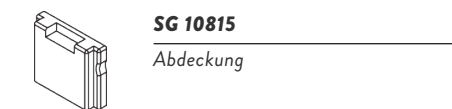

SG 10815

Abdeckung

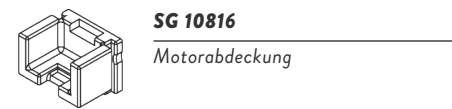

SG 10816

Motorabdeckung



SG 10817

Motorhalterung

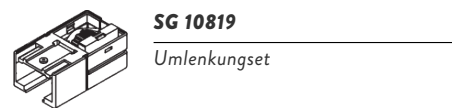

SG 10819

Umlenkungset

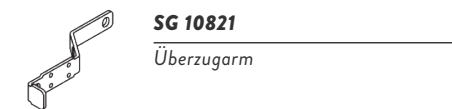

SG 10821

Überzugarm

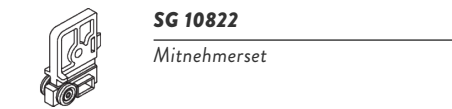

SG 10822

Mitnehmerset

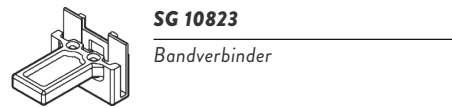

SG 10823

Bandverbinder

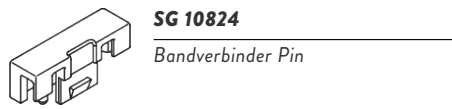

SG 10824

Bandverbinder Pin

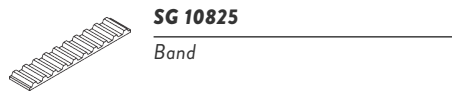

SG 10825

Band

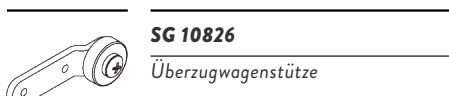

SG 10826

Überzugwagenstütze

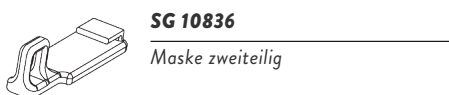

SG 10836

Maske zweiteilig



SG 10837

Vorläuferarm



SG 10838

Vorläuferset

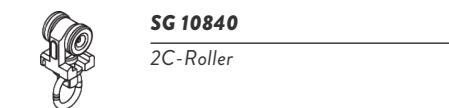

SG 10840

2C-Roller

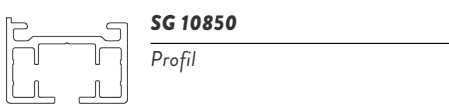

SG 10850

Profil

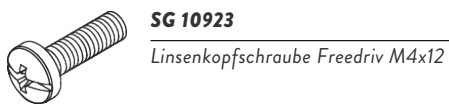

SG 10923

Linsenkopfschraube Freedriv M4x12

B. OPTIONALE KOMPONENTEN



SG 3012

Haken



SG 3041

Träger

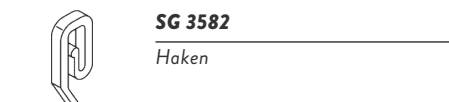

SG 3582

Haken



SG 5118

Klammer



SG 6005

Haken

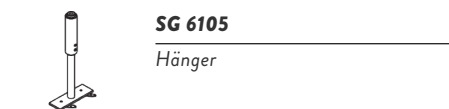

SG 6105

Hänger

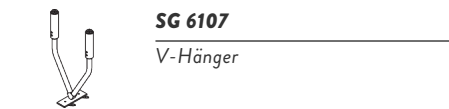

SG 6107

V-Hänger

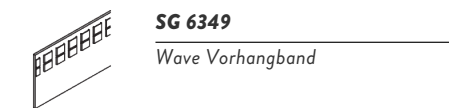

SG 6349

Wave Vorhangband



SG 6363

Wave Bügelband

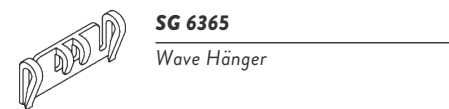

SG 6365

Wave Hänger



SG 7002

Profilschutz

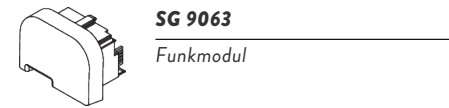

SG 9063

Funkmodul



SG 9916

Hirschmann Kupplungsset

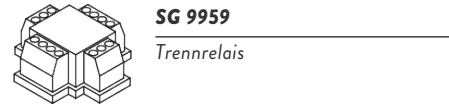

SG 9959

Trennrelais

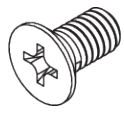

SG 10074
Senkschraube M4x8



SG 10075
Bleischnur 50 gr/m

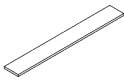

SG 10076
Beschwerung Seitensaum

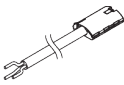

SG 10293
Anschlusskabel 230V AC, 2/3/5/10 m



SG 10300
Funkhandsender 1-Kanal



SG 10302
Funkhandsender 5+1-Kanal



SG 10303
Funkhandsender 10+2+1-Kanal

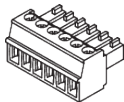

SG 10714
Stecker 6-pin, MC 1.5/6-ST-3.81



SG 10804
Funkhandsender 15+5+1 Kanal

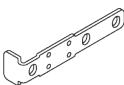

SG 10820
Überzugarm



SG 10831
Profilverbinder

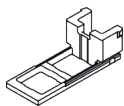

SG 10844
Endposition Motor

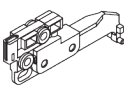

SG 10845
Wave Mitnehmer 80 mm



SG 10852
Wave-2C-Rollerkordel 80 mm

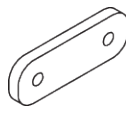

SG 10854
Wave Überzugwagenplatte

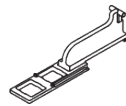

SG 10856
Wave Verlängerung

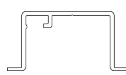

SG 10862
Nutprofil

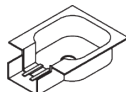

SG 10863
Nutmaske Motor

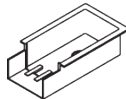

SG 10864
Nutmaske

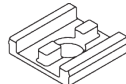

SG 10865
Montageplatte

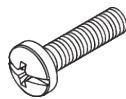

SG 10867
Linsenschraube Freedriv M4x16

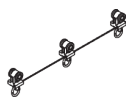

SG 10869
Wave-2C-Rollerkordel 60 mm

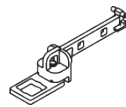

SG 10886
Wave Verlängerung

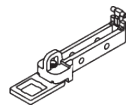

SG 10887
Wave Verlängerung

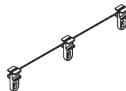

SG 10905
Wave Gleiterkordel 80 mm

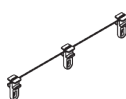

SG 10906
Wave Gleiterkordel 60 mm



SG 10921
Gleiter für direktes Annähen

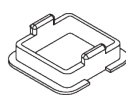

SG 10924
Wave Gleitersupport

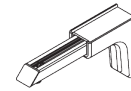

SG 11154
Universal Smart Fix 120 mm

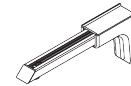

SG 11155
Universal Smart Fix 150 mm

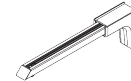

SG 11156
Universal Smart Fix 200 mm



SG 11158
Senkschraube M4x12

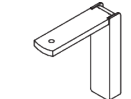

SG 11200
Smart Fix 60 mm

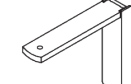

SG 11201
Smart Fix 80 mm

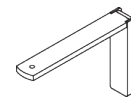

SG 11202
Smart Fix 100 mm

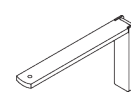

SG 11203
Smart Fix 120 mm

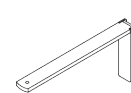

SG 11204
Smart Fix 150 mm

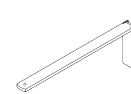

SG 11205
Smart Fix 200 mm

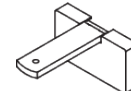

SG 11210
Square Smart Fix 60 mm

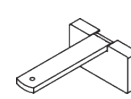

SG 11211
Square Smart Fix 80 mm

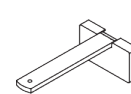

SG 11212
Square Smart Fix 100 mm

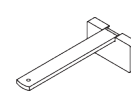

SG 11213
Square Smart Fix 120 mm

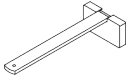
**SG 11214**

Square Smart Fix 150 mm

**SG 11490**

Funkwandsender 5+1-Kanal

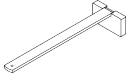
**SG 11215**

Square Smart Fix 200 mm

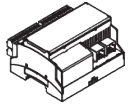
**SG 11260**

Gateway Cedia

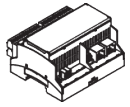
**SG 11261**

Gateway KNX

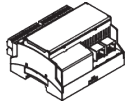
**SG 11262**

Erweiterung

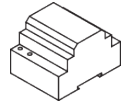
**SG 11264**

Transformer 24V DC, 3.8 Ampere
DIN Rail

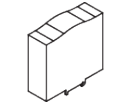
**SG 11265**

Transformer 24V DC, 5 Ampere
DIN Rail

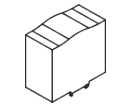
**SG 11266**

Transformer 24V DC, 10 Ampere
DIN Rail

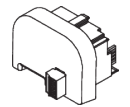
**SG 11270**

Smart Modul

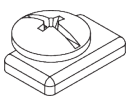
**SG 11295**

Feststeller

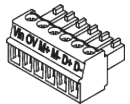
**SG 11325**

Smart Stecker 6-Polig

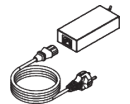
**SG 11414**

Netzteil 24V / 4A C 13 inkl. Kabel
mit EU Stecker

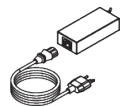
**SG 11415**

Netzteil 24V / 4A C 13 inkl. Kabel
mit CH Stecker

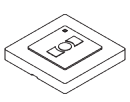
**SG 11480**

Funkwandsender 1-Kanal

